

# THERMOMETER BULKHEAD FOR COOLERS

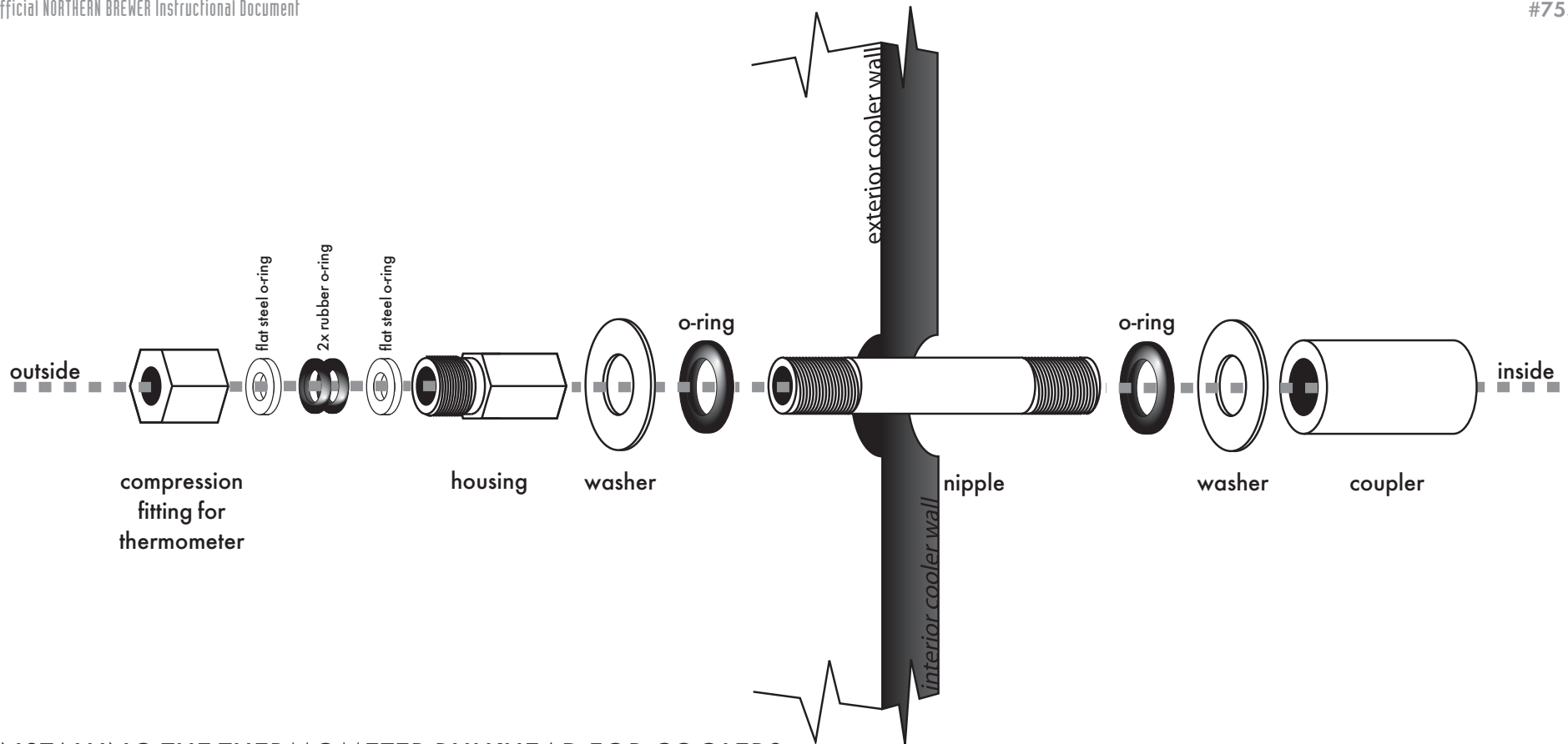

## INSTALLING THE THERMOMETER BULKHEAD FOR COOLERS

1. DRILL A 3/8" HOLE THROUGH THE COOLER WALL.
2. PUT ONE WASHER AND ONE O-RING ON THE COUPLER NIPPLE; HOLDING THE COUPLER INSIDE THE COOLER, PUT THE NIPPLE THROUGH THE HOLE. The o-ring should be against the cooler wall.
3. PUT THE OTHER O-RING ON THE NIPPLE ON THE OUTSIDE OF THE COOLER; PUSH IT AGAINST THE COOLER WALL, AND THEN PUT THE OTHER WASHER ON THE NIPPLE.
4. THREAD THE COMPRESSION FITTING ONTO THE NIPPLE ON THE OUTSIDE OF THE COOLER. Hold the coupler stationary inside the cooler with pliers and tighten the compression fitting from the outside until snug.
5. SLIP THE THERMOMETER STEM THROUGH THE COMPRESSION NUT AND THE SMALL WASHER AND O-RINGS. Omit the washer if the stem is larger than 3/16".
6. PASS THERMOMETER STEM THROUGH NIPPLE AND HAND TIGHTEN THE COMPRESSION NUT.